

### DESCRIPTION

The Series 250 flow sensor from Badger Meter® features a six-bladed impeller design with a proprietary non-magnetic sensing mechanism, mounted in a cast bronze housing, with female NPT threads.

The unique impeller design is less prone to be fouled by waterborne debris. The forward curved shape coupled with the absence of magnetic drag provides improved operation and repeatability even at lower flow rates. This is especially true where the impeller is exposed to metallic or rust particles found in steel or iron pipes. As the liquid flow turns the impeller, a low impedance square wave signal is transmitted with a frequency proportional to the flow rate. The signal can travel up to 2000 ft (610 m) between the flow sensor and the receiving unit without the need for amplification.

All sensors except irrigation versions are supplied with 20 ft (610 cm) of 2-conductor 20 AWG shielded UL type PTLT 221° F (105° C) cable and meet CE standards for noise immunity and susceptibility.

### FEATURES

- Sensor electronics easily removed from the tee
- Impeller, bearing and shaft are easily replaced in the field, without changing calibration
- Two-wire sensor. Power and signal transmit on a single pair of wires, up to a distance of 2000 ft (610 m)
- Digital signal easily interfaced with transmitters, monitors or PLCs

### APPLICATIONS

- Energy management and building management systems
- BTU sub-metering systems
- Cooling tower treatment systems
- Condensate return lines

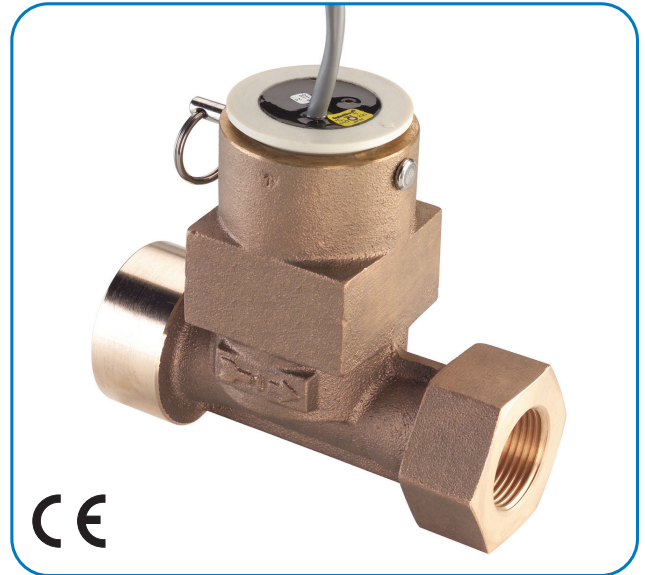

### SPECIFICATIONS

<b>Wetted Materials</b>	See "Part Number Construction" on page 3
<b>Tee for 250B</b>	Cast valve bronze, UNS C83600
<b>Maximum Temperature</b>	Standard electronics: 221° F (105° C) Irrigation electronics: 150° F (66° C)
<b>Maximum Pressure at 100° F</b>	400 psi
<b>Recommended Design Flow Range</b>	0.3...15 ft/sec (0.15...9 m/sec)
<b>Accuracy</b>	± 1.0% of rate
<b>Repeatability</b>	± 0.7% over recommended design flow range
<b>Linearity</b>	± 0.7% over recommended design flow range
<b>Rangeability</b>	60:1
<b>Transducer Excitation</b>	Supply voltage = 8V DC min. 35V DC max. Quiescent current = 600 uA (typical) OFF State ( $V_{High}$ ) = Supply voltage - (600 uA * Supply impedance) ON State ( $V_{Low}$ ) = 1.2V DC @ 40 mA (15 Ω + 0.7V DC)
<b>Electrical Cable for IR Sensor Electronics</b>	48 in (122 cm) of UL style 116666 copper solid AWG 18 wire with direct burial insulation. Rated to 221° F (105° C).
<b>Electrical Cable for Standard Sensor Electronics</b>	20 ft (610 cm) of 2-conductor AWG 20 with AWG 22 drain wire shielded UL type PTLT wire provided for connection to display or transmitter unit. Rated to 221° F (105° C). May be extended to a maximum of 2000 ft (610 m) with similar cable and insulation appropriate for application.
<b>Certifications</b>	CE certified

**DIMENSIONS**

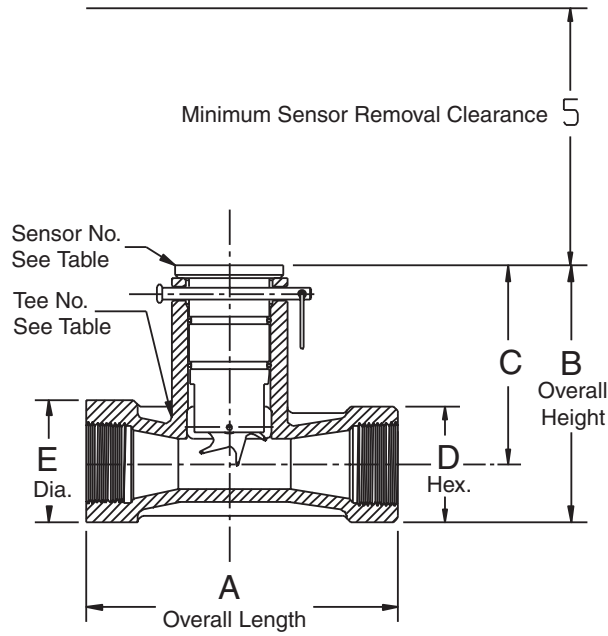

Series No. Complete	Sensor No.	Tee No.	NPT	A	B	C	D	E
250B-0.5	See Matrix	813168T	1/2 - 14	4.0 in. (102 mm)	4.67 in. (119 mm)	3.61 in. (92 mm)	N/A	1.63 in. (41 mm)
250B-0.75	See Matrix	813169T	3/4 - 14	4.0 in. (102 mm)	4.67 in. (119 mm)	3.61 in. (92 mm)	N/A	1.63 in. (41 mm)
250B-1.0	See Matrix	81940T	1.00 - 11.5	5.45 in. (138 mm)	4.75 in. (121 mm)	3.75 in. (95 mm)	2.0 in. (51 mm)	2.12 in. (54 mm)
250B-1.25	See Matrix	81941T	1.25 - 11.5	6.06 in. (154 mm)	5.0 in. (127 mm)	3.88 in. (99 mm)	2.25 in. (57 mm)	2.38 in. (60 mm)
250B-1.5	See Matrix	811193T	1.50 - 11.5	6.5 in. (165 mm)	5.19 in. (132 mm)	3.94 in. (100 mm)	2.5 in. (64 mm)	2.62 in. (67 mm)

Figure 1: Dimensions

## PART NUMBER CONSTRUCTION

### Standard Sensor

Example: 2	50	BR	05	0	5	-	1	2	1	1
<b>STYLE</b>										
Cast Bronze Tee	50									
<b>MATERIAL</b>										
Brass		BR								
<b>SIZE</b>										
0.5"			05							
0.75"			07							
1"			10							
1.25"			12							
1.5"			15							
<b>ELECTRONICS HOUSING</b>										
PPS				0						
<b>ELECTRONICS</b>										
Standard Flow (STANDARD)					5					
IR-Irrigation					6					
<b>O-RING</b>										
Viton®							0			
EPDM (STANDARD)							1			
Buna N							8			
<b>SHAFT</b>										
Zirconia Ceramic									0	
Tungsten Carbide (STANDARD)									2	
316 Stainless Steel									6	
<b>IMPELLER</b>										
Nylon (STANDARD)										1
Tefzel®										2
<b>BEARING</b>										
UHMWPE (STANDARD)										1
Tefzel®										2
Teflon®										3

### High Temperature Sensor

Example: 2	50	BR	05	4	8	-	0	2	2	3
<b>STYLE</b>										
Cast Bronze Tee	50									
<b>MATERIAL</b>										
Brass		BR								
<b>SIZE</b>										
0.5"			05							
0.75"			07							
1"			10							
1.25"			12							
1.5"			15							
<b>ELECTRONICS HOUSING</b>										
PEEK				4						
<b>ELECTRONICS</b>										
High Temperature					8					
<b>O-RING</b>										
Viton®							0			
<b>SHAFT</b>										
Tungsten Carbide									2	
<b>IMPELLER</b>										
Tefzel®										2
<b>BEARING</b>										
Teflon®										3

**Control. Manage. Optimize.**

Data Industrial is a registered trademark of Badger Meter, Inc. Other trademarks appearing in this document are the property of their respective entities. Due to continuous research, product improvements and enhancements, Badger Meter reserves the right to change product or system specifications without notice, except to the extent an outstanding contractual obligation exists. © 2021 Badger Meter, Inc. All rights reserved.

[www.badgermeter.com](http://www.badgermeter.com)